

PRODUCT DATA SHEET

**MICROPROFILE SMD
LINE MATCHING TRANSFORMER****320SMD****Features**

- * Surface Mount
- * Lead-free (Pb-free)
- * RoHS compliant
- * 7mm Seated Height
- * IEC 60950 and UL 60950 Certified
- * UL Recognized Component

Applications

- * Telecommunications
- * Portable computers
- * Fax/Modems

DESCRIPTION

320SMD is a microprofile transformer for applications where high performance and safety isolation to international standards are required in an extremely small case size.

Designed specifically as a surface mount device, the 320SMD features a 7mm seated height and is vacuum encapsulated.

320SMD is certified to IEC 60950 and UL 60950, and is a UL Recognized Component. The part is completely lead-free, compliant with RoHS Directive 2002/95/EC, and suitable for lead-free and conventional processing.

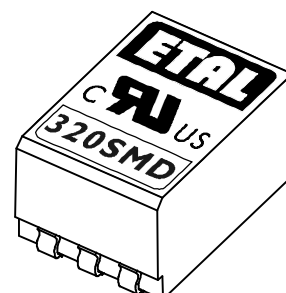
**RoHS**
COMPLIANT

SPECIFICATIONS

Electrical

At T = 25 °C and with 600Ω source and load unless otherwise stated.

Parameter	Conditions	Min	Typ	Max	Units
Insertion Loss	f = 1kHz	-	-	2.0	dB
Frequency Response	300Hz – 3.4kHz	-	-	±0.1	dB
Return Loss	Circuit figure 2 200Hz – 4kHz	20	-	-	dB
Harmonic Distortion ⁽¹⁾	400Hz, -10dBm on primary	-	-78	-62	dBc
Voltage Isolation ⁽²⁾	50Hz/60Hz	3.88	-	-	kVrms
	DC	5.5	-	-	kV
Operating Range: Functional Storage ⁽⁵⁾		-25	-	+70	°C
		-40	-	+125	°C

Lumped equivalent circuit parameters as Fig. 1

DC resistance ⁽³⁾	Primary resistance R_{DCP}	64	75	86	Ω
	Secondary resistance R_{DCS}	64	75	86	Ω
Leakage inductance, ΔL		-	3.5	7.0	mH
Shunt inductance, L_p ⁽⁴⁾	300Hz 25mV	1.6	-	-	H
Shunt loss, R_p ⁽⁴⁾	300Hz 25mV	5.0	-	-	kΩ

Notes:

1. Third harmonic typically exceeds other harmonics by 20dB.
2. Components 100% tested at 6.5 kVDC.
3. **Caution:** do not pass DC through windings.
4. At signal levels greater than 100mV, L_p will increase and R_p will decrease slightly but the effect is usually favourable
5. Excludes shipping materials. Components are dry-packed and sealed as shipped. Handle in accordance with IPC/JEDEC J-STD-033 procedure for components classified as IPC/JEDEC J-STD-020 Moisture Sensitivity Level 5a.

Equivalent Circuit

Fig 1

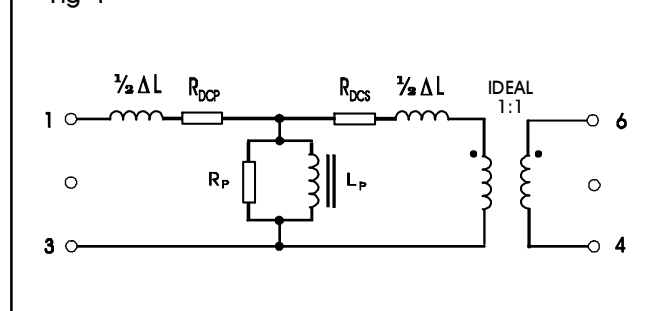

REFERENCE CIRCUIT

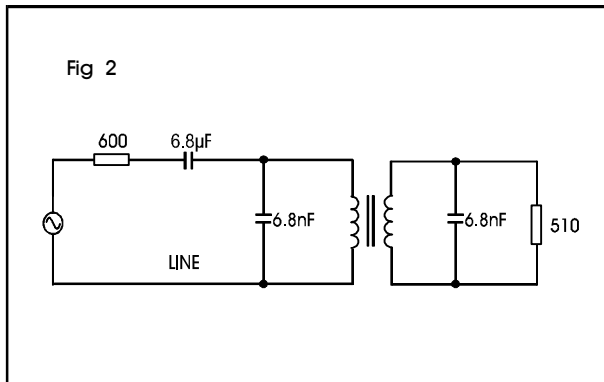

CONSTRUCTION

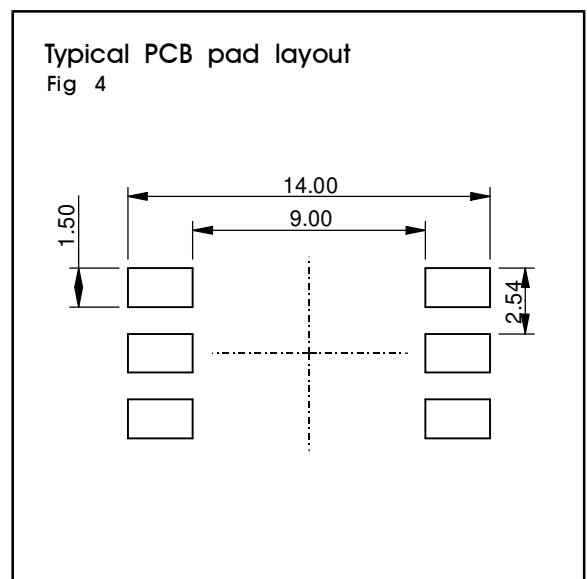
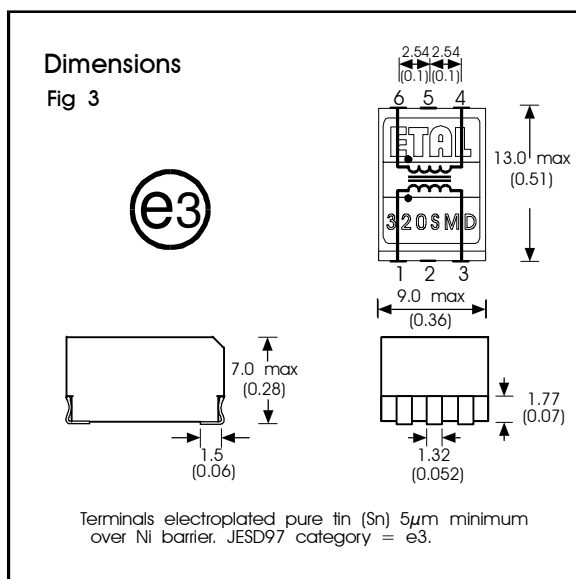

Dimensions shown are in millimetres (inches).
Geometric centres of outline and pin grid coincide within a tolerance circle of 0.3mmØ.
Windings may be used interchangeably as primary or secondary.

ABSOLUTE MAXIMUM RATINGS

(Ratings of components independent of circuit).

Short term isolation voltage (2s) 4.6kVrms,
6.5kVDC

DC current
(avoiding distortion impairment) 100µA

Storage temperature -40°C to
+125°C

Soldering temperature
Profile peak 260°C 10s

Recommended peak body temperature 245°C in
accordance with IPC/JEDEC J-STD-020.

SAFETY

Manufactured from materials conforming to
flammability requirements of UL94V-0.

Distance through reinforced insulation 0.4mm
minimum.

Construction complies with IEC 60950-1, Second
Edition, reinforced insulation, 250Vrms maximum
working voltage.

CERTIFICATION

Certified under the IEC CB Scheme (Certificate
DK-15467) to IEC 60950-1:2005 sub-clauses
1.5, 1.7, 2.9, 2.10, 4.7 and 5.2 (Denmark,
Finland, Germany, Norway, Ireland, Korea,
Spain, Sweden, Switzerland, USA, Canada and
UK national deviations) for a maximum working
voltage of 250Vrms, nominal mains supply
voltage not exceeding 250Vrms and a maximum
operating temperature of +70°C in Pollution
Degree 2 environment, reinforced insulation.

Recognized under the Component Recognition
Program of Underwriters Laboratories Inc.
to US and Canadian requirements
CAN/CSA C22.2 No. 60950-1/UL60950-1, Second
Edition, based on IEC 60950-1, Second Edition,
maximum working voltage 250Vrms, Pollution
Degree 2, reinforced insulation.

UL File number E203175.

Additionally, ETAL certifies all transformers as
providing voltage isolation of 3.88kVrms, 5.5kV
DC minimum. All shipments are supported by a
Certificate of Conformity to current applicable
safety standards.

ORDERING CODE

320SMD□□



TR = Tape and Reel
(Blank) = Bulk in tubes.

Carrier tape width 24mm,
500 parts per 13" reel.

COPYRIGHT

ETAL is the Trade Mark of Profec Technologies
Ltd (wholly owned by ElektronikGruppen BK AB).
The Trade Mark ETAL is registered at the UK
Trade Marks Registry.
Profec Technologies Ltd is the owner of the
design right under the Copyright Designs and
Patents Act 1988 and no rights or licences are
hereby granted or implied to any third party.

British Patent No. 2283195

US Patent No. 5879598

European Patent No. 0725719

© 1997 - 2009 ETAL Group AB.

Reproduction prohibited.